

SEISMIC PERFORMANCE ANALYSIS OF WENCHUAN HOSPITAL STRUCTURE WITH VISCOUS DAMPERS

XUE-WEI CHEN^{1*}, JIA-XUAN LI¹ AND JACK CHEANG²

¹*School of Civil Engineering and Transportation, South China University of Technology Guangzhou, China*

²*Advanced Building Technology Company, Guangzhou, China*

SUMMARY

Analytical investigation was undertaken to assess the seismic performance of Wenchuan Hospital located in Wenchuan county, southwest China's Sichuan province, where a severe earthquake has occurred in May 2008. The structure consists of a four-storey reinforced concrete frame with viscous dampers. The irregular building is 18.35-m tall and has a total floor area of 17 000 m². Viscous dampers are set along the outside surface of structure to get a more efficient reduction of structure responses. The design idea of performance-based seismic design is presented in this paper. Seismic performance of the structure with and without viscous dampers under different levels of ground motion is analysed and verified by different methods, including elastic analysis under frequent earthquake, unyielding and elastic check of structure element under medium earthquake, static nonlinear analysis and dynamic nonlinear analysis under rare earthquake. And a comparative analysis is presented, such as results between elastic and inelastic analysis, static nonlinear analysis and dynamic nonlinear analysis, and structure with and without viscous dampers. The control effects of viscous dampers on internal force, deformation and energy dissipation of the structure are also studied. Meanwhile, a practical method to calculate the supplemental damping ratio added by viscous dampers is proposed for elastic analysis with dampers. After a series of analysis, the performance objective of the structure can be well verified. Copyright © 2010 John Wiley & Sons, Ltd.

1. INTRODUCTION

The Wenchuan Hospital project in Weizhou Town of Wenchuan County is the first batch of public building projects supported by Guangzhou, and is also an important part of the program Earthquake Reconstruction Statute for Wenchuan. A severe earthquake has occurred in Wenchuan town in May 2008, and even now Wenchuan is still suffering a series of aftershocks. The Wenchuan Hospital project has a building area of 20 000 m² which is composed of the Wenchuan Hospital (17 000 m²), First Aid Center (2500 m²) and Rehabilitation Centre (500 m²). Wenchuan Hospital is a building with four storeys, which has been put into operation in 31 October 2009, as shown in Figure 1.

Wenchuan Hospital is 18.35-m tall and has four storeys with some stairhoods on the top. The first storey is 5-m high; typical-storey is 4.45-m high; and stairhood is 3.55-m high. The building has an irregular shape which is composed of two parts; the top part of the building is 82.4 × 20.7 m², and the bottom part of it is 32.1 × 47.7 m², as shown in Figure 3. Due to the importance of the building, it is designed by the advanced design method 'Performance-based seismic design of building', and the reinforced concrete (RC) frame with viscous dampers is adopted as lateral-resisting structure system. A Etabs model of the structure is shown in Figure 2.

* Correspondence to: CHEN XUE-WEI, South China University of Technology, Room 301, Construction Training Building, Wu Shan Street, Galaxy District, Guang Zhou, CN 510640, China. E-mail: dinochen1983@yahoo.com.cn



Figure 1. Rendering view of Wenchuan Hospital

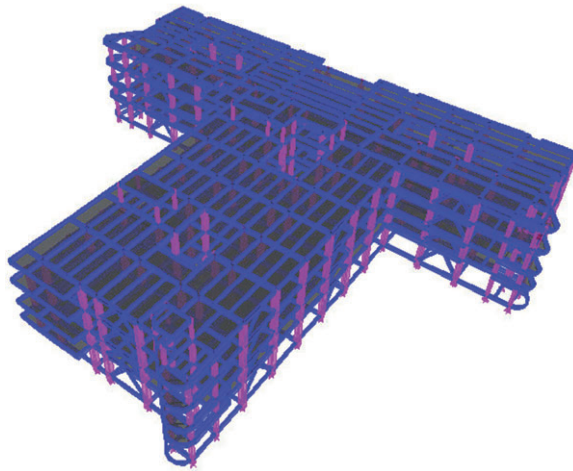

Figure 2. ETABS model of the building

Columns in three staircases or elevator rooms have a section of $500 \times 500 \text{ mm}^2$ overall the length; the other columns have a section of $800 \times 800 \text{ mm}^2$ in the first and second storeys, and change the dimensions as $700 \times 700 \text{ mm}^2$ in the third and fourth storeys. Besides, the columns in the stairhood on the top have a small section of $300 \times 400 \text{ mm}^2$, and some of these are supported by frame beams. A casting-reinforced concrete beam and slab floor are adopted in this structure. Most of the frame beams have a section of $350 \times 750 \text{ mm}^2$, and change the dimensions as $350 \times 800 \text{ mm}^2$ or $300 \times 900 \text{ mm}^2$ in the hall; otherwise, most of secondary beams have a section of $250 \times 600 \text{ mm}^2$. A 110-mm thick floor slab is adopted somewhere with a 120-mm thickness, and the roof slab is 100 mm thick. Concrete with a grade C30 is adopted in all slabs, beams and columns with an exception on columns connected with braces and dampers in which a grade C35 is adopted to strengthen the connection.

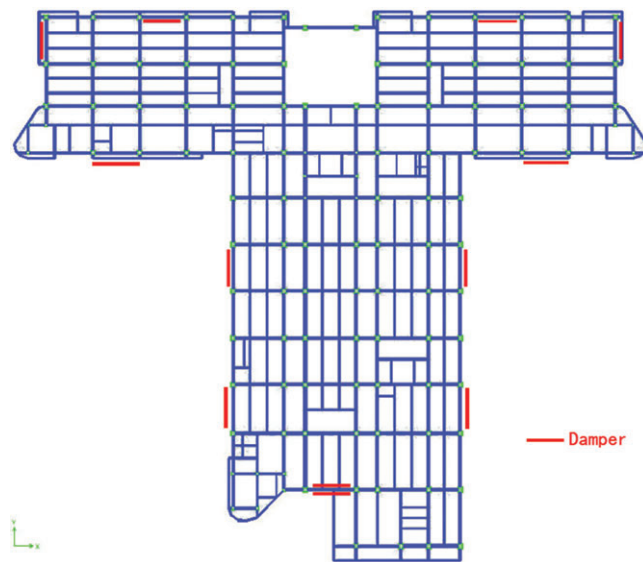

Figure 3. Building plan of storey 1

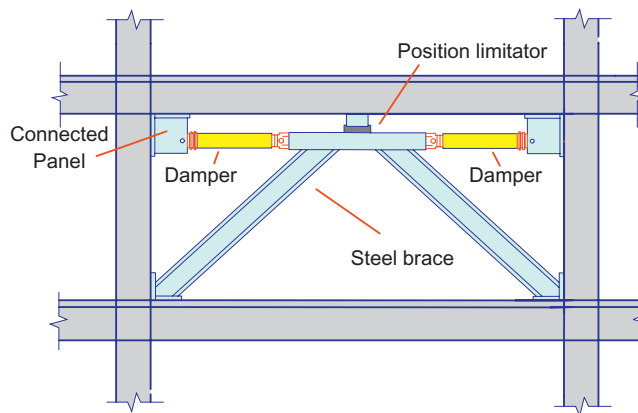

Figure 4. K-Brace-Damper System

As it is known that this strategy of damper positioning has a better efficiency in reducing the response of structures, especially in reducing the torsion effects of structure, 46 viscous dampers are set along the outside surface of structure. Dampers are set up overall the structure's height, and the positioning of them are shown in Figure 3. All dampers are set up in the form of K-Brace-Damper System, as shown in Figure 4. There is a special span having two dampers connecting one K-Brace, as shown in Figure 3. And each K-Brace in other spans is connected with only one damper. Besides, the installation of viscous damper is shown in Figure 5, and damper's parameters are listed as follows: damping exponent $\alpha = 0.1$; damping coefficient $C_d = 1250 \text{ kN}/(\text{m/s})^\alpha$; maximum allowable damping force is 1000 kN; maximum allowable damping deformation is $\pm 100 \text{ mm}$.



Figure 5. Installation of viscous damper

Table 1. Gravity load

Position	Live load (kN/m ²)	Additional dead load (kN/m ²)
Patient room	6.5	1.5
Operation room	3.0	1.5
Equipment room	5.0	1.5
X-ray room	5.0	1.5
Outdoor garden	6.5	6.0
Toilet	6.5	8.0
Roof	2.0	2.5

Additional dead load has considered partition's free span.

2. LOAD AND LOAD COMBINATION

2.1 Gravity loads

According to the Load Code for the design of Building Structures (GB50009-2001) (National Standard of PRC, 2002), gravity loads are taken and the values are listed in Table 1.

2.2 Seismic action

Parameters of seismic action are as follows: design reference period, 50 years; seismic fortification intensity, 8 degree; seismic classification, B-class (Key fortification building); frame seismic design level-1; structure safety grade, 2nd grade; design basic acceleration of ground motion, 0.2 g; seismic design classification, 1st group; site classification, II-class; characteristic period of ground motion, 0.35 s. According to the Code for Seismic Design of Buildings (GB50011-2001) (National Standard of PRC, 2001) (hereafter the Seismic Code for short) and take the General rule for performance-based seismic design of buildings (CECS160:2004) (National General Rule of PRC, 2004) as a reference, parameters of seismic analysis are listed in Table 2.

In trial calculation, 32 groups of two-way natural seismic waves are adopted in elastic model which is modelled in ETABS. Based on comparison of base shear result from time-history analysis and

Table 2. Parameters of seismic analysis

Seismic intensity	Exceeding probability based on design reference period of 50 years (%)	Earthquake affecting coefficient	Peak acceleration (cm/s^2)
Frequent earthquake	63	0.16	70
Medium earthquake	10	0.46	200
Rare earthquake	2	0.90	400

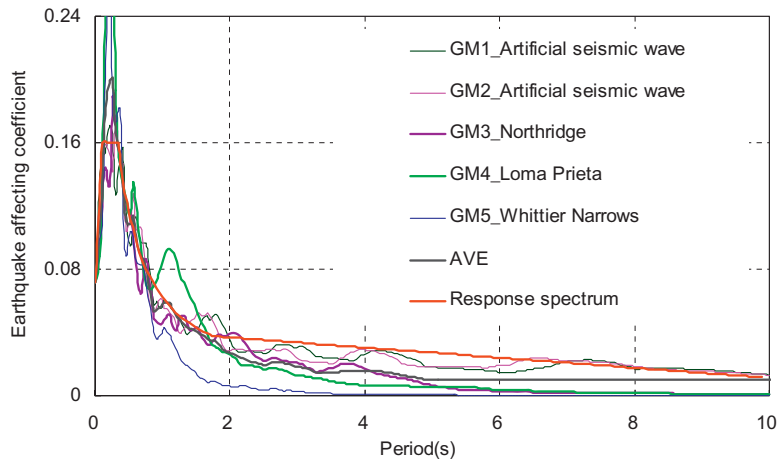

Figure 6. Comparison of response spectrum from the seismic code and seismic waves

response spectrum analysis, these seismic waves, two groups of artificial seismic waves and three groups of natural seismic waves, which meet the needs of the seismic code, are chosen. The screening conditions are as follows: base shear result of time-history analysis under single wave should be no less than 65% of the result from response spectrum analysis and the mean value of base shear results obtained from time history analysis with the chosen waves should be no less than 80% of the result obtained from response spectrum analysis. Response spectrum of dominate wave from each chosen group and response spectrum described in the seismic code are shown in Figure 6, from which we can see that, nearby the characteristic period of ground motion ($T_g = 0.35$ s) and the structure nature vibration period ($T_1 = 0.69$ s), the mean value of response spectrums gained from seismic waves is marched well with the value of response spectrum described in the seismic. According to ASCE 7-05 (American Society of Civil Engineers, 2006) and the newest American Code for performance-based seismic design of building (Structural Engineers Association of Northern California, 2007), it is reasonable to take the mean value of structure and structure ductile members envelope responses gained from the chosen seismic waves as the seismic responses reference value. In order to have a better inspection of structure seismic performance, two directions of horizontal input are taken into account as follows: 0° (X-direction), 90° (Y-direction) and two-way seismic action is taken into consideration.

2.3 Wind load

According to the Load code for the design of Building Structures (GB50009-2001), values of basic wind pressure in Wenchuan is listed as follows: return period of 100 years for bearing capacity analysis, $w_0 = 0.35 \text{ kN/m}^2$; ground roughness, B-class; and structure shape factor $\mu_s = 1.3$. In contrast with seismic action, it is certified that the wind load is not the controlling factor in the structure's performance. Hence, only seismic performance of the hospital building is shown in this paper.

2.4 Load combination

All structure elements should be designed under the most unfavourable load combination. Partial coefficient for the loads, internal force magnification and adjustment coefficient of elements and structure should be taken into account according to current codes, and partial coefficient for the loads can be taken from code. Under medium earthquake action, elements of structure without dampers should be ensured under elastic or unyielding limit, respectively. Under rare earthquake action, as to the important part of the structure such as columns of bottom strengthened region, their shear and flexural capacity should be ensured under unyielding limit; as to those important girders, their shear capacity should be ensured under unyielding limit; flexural capacity of these elements and shear and flexural capacity of frame beam can be designed in yielding state, but they should have a deformation check according to ASCE-II (American Society of Civil Engineers, 2007).

3. ANALYSIS MODEL IN PERFORM-3D

3.1 Material model

3.1.1 Concrete model

Mander concrete model (Bai *et al.*, 2002) is most frequently used to describe working condition of confined concrete in uniaxial compression, which is related with section shape and the configuration condition of stirrup. In Perform-3D, we must transfer the model in the standard force–deformation relationship (Computer and Structures Inc., 2006) which can be determined by five parameters. Hence, concrete model curve adopted in the structure in different confined condition by stirrup can be computed according to the Mander model, mean value of concrete's strength and elastic modulus, as shown in Figure 7.

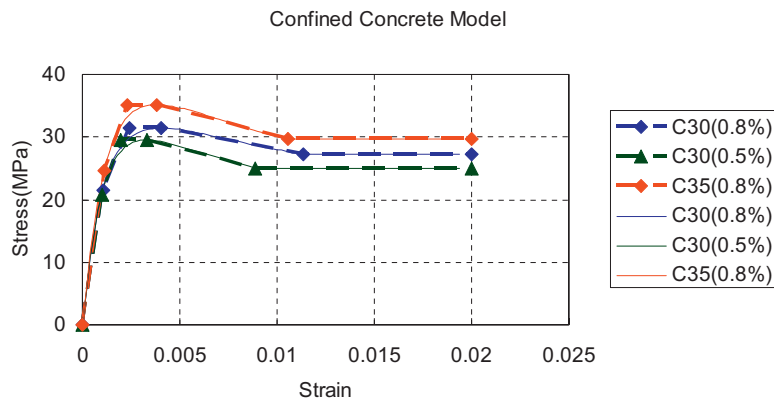

Figure 7. Stress–strain relationship of confined concrete with different volum-stirrup ratio

3.1.2 Steel model

Steel model with bulking or non-bulking are available in Perform-3D. The ductility design is mainly based on two facts: (a) the stress of reinforcement is still in high level after experiencing cyclic large plastic strain; and (b) a requirement that reinforcement cannot be abrupt brittle is assumed. Hence, non-bulking bilinear steel model is always used to model the reinforcement in the RC frame. Herein, HRB335 with a strength of 335 MPa are adopted in structure member.

3.1.3 Hysteretic model

It is known that energy can be dissipated by nonlinear component under cyclic loading, and the amount of the dissipated energy can be represented by the area of hysteretic loop. Hence, to a great extent, the structural response can be differed by the area and shape of hysteretic loop. In Perform-3D, parameters of energy degradation are determined by the maximum deformation and can be specified optionally, as shown in Figure 8. Perform-3D gives the required energy degradation through adjusting the unloading-load stiffness, and the coefficient of energy degradation is taken as the ratio of the area of degraded and non-degraded hysteretic loop, which can be obtained from experiment and numerical simulation. In this paper, parameters of energy degradation is defined according to the degradation rule of unloading-load stiffness in Mander model, as shown in Figure 9, while that of reinforcement in all strength region is taken as 1.0.

3.1.4 Elastic damping

Mechanical energy through which energy is dissipated for elastic structure, is always simulated as viscous damping; if the structure has yielded, energy can be more efficiently dissipated through the nonlinear behaviour of component, and the dissipated energy can be measured as the area of hysteretic loop. While the structural energy is not equal to the hysteretic energy, plenty of elastic energy in structure are simulated as viscous damping (Rayleigh damping). The difference of damping between

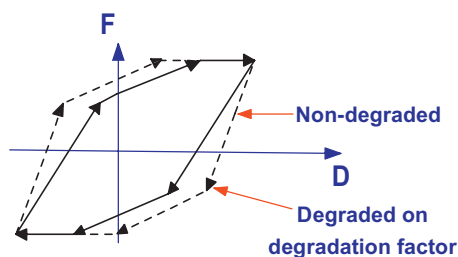

Figure 8. Hysteretic loop of energy degradation

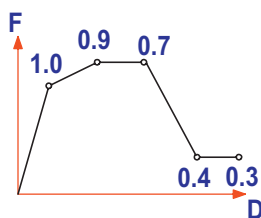

Figure 9. Degradation coefficients of concrete

plastic hinge model and fibre model is presented as follows: (a) for plastic hinge model, additional damping would not be imported before plastic hinge being deformed; in other words, no additional damping will be imported in the initial elastic state; and (b) for fibre model based on multi-polyline material model, additional damping can be computed automatically in the whole deformation process by the cracking, yielding and failure state of fibre. The latter is better than the former in the numerical simulation of damping.

3.1.5 Time history integral algorithm

In Perform-3D, dynamic equilibrium equation expressed in the form of Δt as $M\Delta\ddot{r} + C\Delta\dot{r} + K\Delta r = \Delta R$, can be solved by step-by-step method. For there are three unknown variables ($\Delta\ddot{r}$, $\Delta\dot{r}$, Δr), some assumptions for the solving process must be proposed. Hence, the result is approximate. Besides, a step-by-step method named Constant Average Acceleration is adopted in Perform-3D.

3.2 Element models in Perform-3D

3.2.1 Beam-Column element model

Perform-3D provides many kinds of beam-column element model, including plastic hinge model and fibre model. The latter is adopted in this paper. The characteristics of fibre model are presented as follows:

- (1) Force–deformation relationship of beams and columns is converted as the stress-strain relationship of concrete and reinforcement.
- (2) Shear deformation is taken into consideration in Timoshenko beam element.
- (3) A freely selecting input mode of the fiber division is available, by which confined and non-confined concrete fiber and complex composite section can be inputted. Typical sections of the beam-column fiber are shown in Figure 10.

In Perform-3D, a function of section assembly for beam-column component, which can increase the number of integral points along element length without increasing the number of degrees, is also provided, and the calculation accuracy and effect can be improved. Beam-column element is usually divided into end plastic region model and multi-segment plastic region mode based on different component assembly as shown in Figure 11. If element is divided reasonably, it can save computing time when end plastic region model is adopted under the premise of accuracy. Besides, a shear hinge can be added to consider nonlinear shear deformation and shear failure induced by large shear forces acting on the beam component.

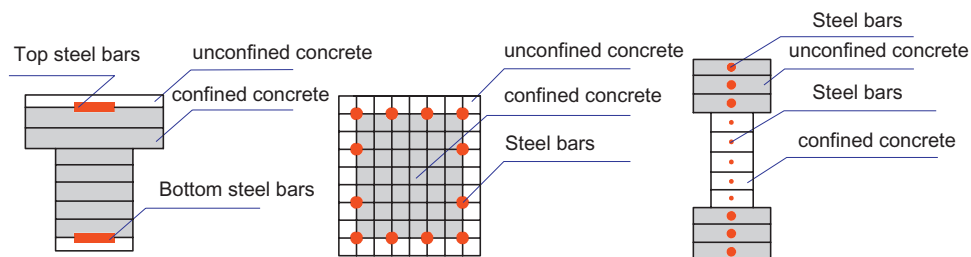

Figure 10. Fiber of beam and column and shear wall

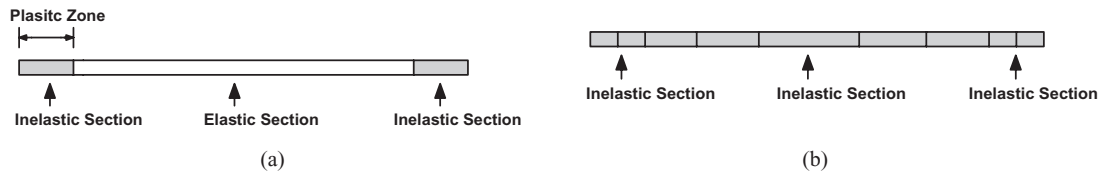

Figure 11. Assembly of beam-column component: (a) end plastic region model; (b) multi-segment plastic region model

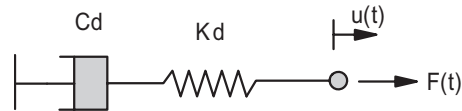

Figure 12. MAXWELL Model

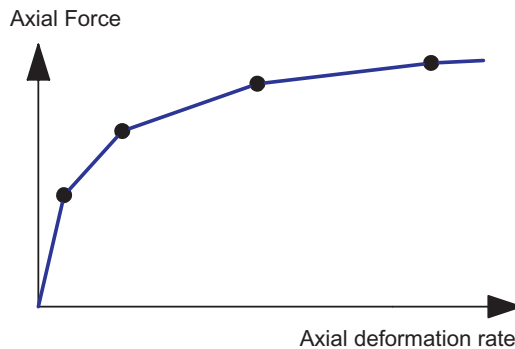

Figure 13. Damper properties

3.2.2 Viscous bar element model

In Perform-3D, a viscous bar element is composed of one linear elastic bar component and one damper component. And the viscous damper can be well described by using the MAXWELL model under small deformation (Constantinou and Symans, 1992). As shown in Figure 12, the spring represents the linear elastic bar which has a stiffness $K_d = EA$, where $E = \text{Young's modulus}$ and $A = \text{bar area}$; and the piston represents the damper which has a damping coefficient C_d and has no elastic stiffness. Besides, the deformation measure for the linear elastic bar component is *axial strain*, and the axial deformation measure for damper component is *axial extension* which has a relationship between axial force and axial deformation rate shown in Figure 13. It can be clearly seen that five straight line segments, and the tangent damping coefficient, will decrease as the deformation rate increases.

The constitutive relation of viscous damper is explained as follows:

$$f_D = C_d \operatorname{sgn}(\dot{x}) |\dot{x}|^\alpha \quad (1)$$

where $C_d = \text{damping coefficient}$; $\alpha = \text{damping exponent}$ which usually has a value range 0.1~1.0 in building structures; $\operatorname{sgn}(\dot{x})$ is a sign function. As usual, a value range 0~1 m/s of the forced reaction rate is reasonable for the viscous dampers in building structures, and some correlational researches

(Taylor, 2007) show that viscous dampers will go in an efficient working condition when $\alpha = 0.1\text{--}0.3$ and forced reaction rate in a small range is $0\text{--}0.3$ m/s.

4. STRUCTURE SEISMIC ANALYSIS

4.1 Performance objective

Structure is analysed in three levels of seismic action: frequent earthquake, medium earthquake and rare earthquake. Take ASCE-41 as a reference, according to performance level of element ductility (nonductility); performance level of structure can be described in four levels as follows: (a) operational (OP); (b) immediate occupancy (IO); (c) life safety (LS); and (d) collapse prevention (CP), as shown in Figure 14.

Due to the importance of Wenchuan Hospital, macro-performance objective of structure are proposed as follows:

- (1) A structure without damper device should remain elastic under frequent earthquake, unyielding under medium earthquake and non-collapse under rare earthquake.
- (2) A structure with damper device should remain elastic under frequent earthquake and medium earthquake, unyielding under rare earthquake. According to the American Code Federal Emergency Management Agency (FEMA356) and Chinese regulations CECS160 and having an incorporation with engineering practice in China, performance objectives of members are proposed based on a mature consideration about loading and deformation condition of all parts of structure, as shown in Tables 3 and 4.

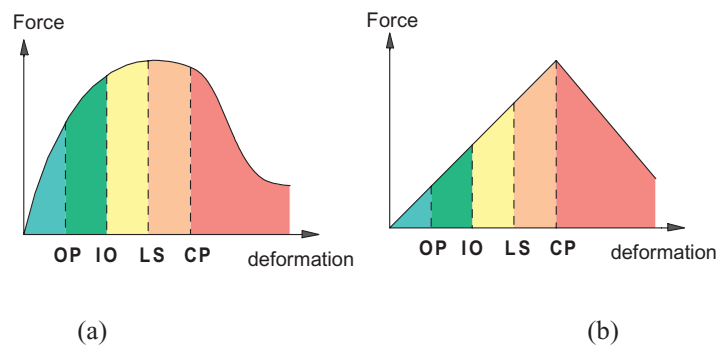

Figure 14. Member's performance level: (a) ductile member; (b) brittle member.

Table 3. Performance objectives of structure and members

Type		Frequent earthquake	Medium earthquake	Rare earthquake
Frame column	Without dampers	OP	IO	LS
	With dampers	OP	OP	IO
Frame beam	Without dampers	OP	LS	CP
	With dampers	OP	IO	LS
Secondary beam	—	IO	LS	CP
Brace and damper	—	Safe work condition		
Storey drift	—	1/1000	1/500	1/200

CP, collapse prevention; IO, immediate occupancy; LS, life safety; OP, operational.

Table 4. Deformation value for performance levels

Element type	Rotation (rad)		
	IO	LS	CP
Frame column	0.005	0.015	0.02
Frame beam	0.005	0.015	0.02
Secondary beam	0.005	0.02	0.03

CP, collapse prevention; IO, immediate occupancy; LS, life safety.

Table 5. Contrastive analysis of each model

Software	Total mass (ton)	Period (s)			
		T ₁	T ₂	T ₃	T ₄
ETABS	20 910.0	0.687	0.669	0.638	0.279
Perform-3D	20 860.0	0.714	0.708	0.669	0.235

Table 6. Main performance under frequent earthquake

Analysis method	Response spectrum analysis		Dynamic history analysis			
	Without dampers		Without dampers		With dampers	
	0	90	0	90	0	90
Condition						
Direction (°)						
Maximum storey drift (rad)	1/1191	1/1114	1/1121	1/1042	1/4424	1/4554
Top displacement(mm)	13.4	13.8	13.5	14.3	2.2	2.1
Base shear (kN)	14 147	13 585	14 235	13 593	4585	4230
Base moment (kN/m)	194 988	187 919	193 321	190 486	38 950	38 364

Two structural analysis softwares (ETABS, Perform-3D) have been used for a comparative analysis. To ensure the reliability of models, results of modal analysis and under gravity load from each model are contrasted, as shown in Table 5.

4.2 Structure analysis under frequent earthquake

The structure is in elastic state under frequent earthquake according to bearing capacity check, so elastic model in ETABS is adopted. Besides, ETABS V9.1.2 provides a Fast Nonlinear dynamic history Analysis method (FNA) (Computer and Structures, Inc., 2007) which can well describe the response of structure with energy dissipated device. Both response spectrum analysis and dynamic history analysis are carried out for the structure without and with dampers, and results are compared in Table 6, and the comparison is shown in Figure 15.

The analysis results show that:

- (1) Average response of dynamic history analysis results with chosen earthquake waves can well meet response spectrum analysis results.
- (2) Structures with and without dampers meet the performance objective listed in Table 3.
- (3) The responses of structure can be well weakened (as shown in Table 6 and Figure 15) by adding viscous dampers which have an energy dissipated rate of about 93% of input energy.

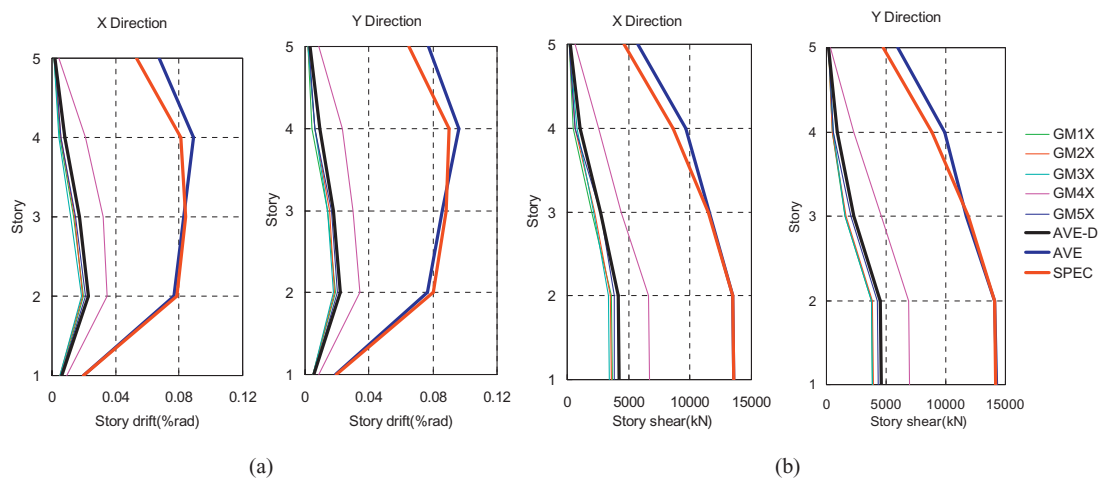

Figure 15. Structure performance under frequent earthquake (with dampers): (a) storey drift curve; (b) storey shear curve. AVE-D, average response of structure with dampers; AVE, average response of structure without dampers; SPEC, response of elastic model with response spectrum analysis

Table 7. Main performance under medium earthquake

Analysis method	Response spectrum analysis		Dynamic history analysis			
	Without dampers		Without dampers		With dampers	
Dampers						
Direction (°)	0	90	0	90	0	90
Maximum storey drift (rad)	1/414	1/387	1/393	1/365	1/963	1/985
Top displacement (mm)	38.4	39.5	38.5	40.8	15.5	16.4
Base shear (kN)	40 673	39 058	40 670	38 838	16 918	16 162
Base moment (kN/m)	560 591	540 267	552 345	544 245	228 932	224 170

4.3 Structure analysis under medium earthquake

Bearing capacity check under medium earthquake is carried out in ETABS, including unyielding and elastic check of structure under medium earthquake. Besides, main performances of structure with and without dampers under medium earthquake are listed in Table 7, and the comparison is shown in Figure 16.

The analysis results show that:

- (1) After bearing capacity check under medium earthquake, structure without dampers cannot remain elastic yet. Storey drift exceeds performance limitation 1/500, and some of the bottom columns (columns in storey-2, part of columns in storey-3) are over-reinforced. However, it can be proved by bearing capacity check that structure without dampers still remains unyielding under medium earthquake.
- (2) Structures with dampers remain elastic which meet the performance objective under medium earthquake, and the storey drift satisfies performance limitation 1/500. Besides, as shown in Table 7, main performances are similar to main performances of structure without dampers under frequent earthquake, and so is the weight of reinforcing bar.

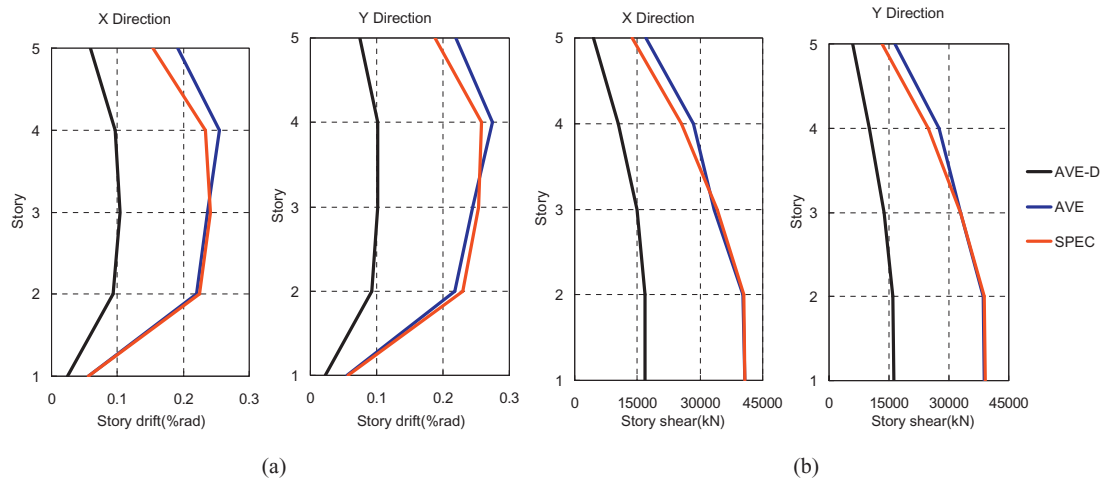

Figure 16. Structure performance under medium earthquake (with dampers): (a) storey drift curve; (b) storey shear curve. AVE-D, average response of structure with dampers; AVE, average response of structure without dampers; SPEC, response of elastic model with response spectrum analysis

- (3) Responses of structure can be well weakened (as shown in Table 7 and Figure 16) by adding viscous dampers which have an energy dissipated rate of about 83% of input energy.

4.4 Supplemental damping ratio in elastic analysis

Viscous damper cannot be taken into account in elastic analysis, including response spectrum analysis and elastic dynamic history analysis. And a supplemental damping ratio of structure contributed by viscous dampers must be set up.

The structure is designed as the performance objective that structure without dampers remains elastic under frequent earthquake and structure with dampers remains elastic under medium earthquake. Hence, only supplemental damping ratio contributed by added viscous dampers under medium earthquake is discussed in this paper.

The formula for calculating the supplemental damping ratio contributed by added energy dissipated device is provided by FEMA273/274 (FEMA, 1997) and FEMA356 (FEMA, 2000) in the form of

$$\xi_{eq} = \sum_j E_j / (4\pi U_t) \quad (2)$$

where E_j = total energy dissipated by energy dissipation device j in a cycle of motion and U_t = maximum potential (strain) energy of the structure.

As to linear dampers:

$$\xi_k = \frac{T_k \sum_j C_j \cos^2 \theta_j (\phi_j - \phi_{j-1})^2}{4\pi \sum_i m_i \phi_i^2} \quad (3)$$

As to nonlinear dampers, based on the principle that the work done by a viscous damper in one cycle of vibration is equated to the energy dissipated by a linear viscous damper, an approximate

formula is proposed by Soong and Constantinou (1994) and Seleemah and Constantinou (1997) (Constantinou *et al.*, 2001):

$$\xi_k = \frac{T_k^{2-\alpha} \sum_j \eta_j C_j \lambda \cos^{1+\alpha} \theta_j (\phi_j - \phi_{j-1})^{1-\alpha}}{(2\pi)^{3-\alpha} A^{1-\alpha} \sum_i m_i \phi_i^2} \quad (4)$$

where ϕ_j and ϕ_{j-1} = the horizontal modal displacements of the j th and $j - 1$ th storey in the k th mode of vibration; T_k = natural period of the k th mode of vibration; C_j = damping coefficients of the dampers at the j th storey; θ_j = inclination angle of the dampers in the j th storey; α = damping exponent; η_j = number of identical dampers with the same C_j in each storey; A = roof response amplitude corresponding to modal displacement ϕ_j normalized to a unit value at the roof; and λ is a calculative parameter.

It is known that higher mode responses will be highly suppressed when sufficient dampers are incorporated into a building structure, especially to the lower multi-storey structure. For simplicity, it is reasonable that the damping ratio of a building structure with added viscous dampers is approximated by the first mode vibration in the direction of consideration. As K-Brace-Damper System is used in this project, the inclination angle of the dampers θ should equal to 0, and Equation (4) has a short form of

$$\xi_1 = \frac{T_1^{2-\alpha} \sum_j \eta_j C_j \lambda \phi_1^{1-\alpha}}{(2\pi)^{3-\alpha} A^{1-\alpha} \sum_i m_i \phi_i^2} \quad (5)$$

A practical method using ETABS V9.1.2 to calculate the supplemental damping ratio added by viscous dampers is proposed in this paper, and the procedure is represented as follows:

- (1) A series of sine wave which has a period the same as the natural period of the first mode of vibration is imported to structure, and peak acceleration of it is rectified to make structure responses meet the anticipative value.
- (2) Energy dissipated by viscous dampers E_d and maximum potential energy U_t can be obtained.
- (3) The supplemental damping ratio added by viscous dampers can be calculated by Equation (2).

In this paper, a sine wave with a peak acceleration of 600 gal in X-direction and a sine wave with a peak acceleration of 550 gal in Y-direction are imported into structure after trial calculation, and both of them have durations with $10T_1$, where T_1 is the first natural period of structure. Then, responses and energy-dissipated condition of structure are obtained, and the supplemental damping ratio added by viscous dampers can be calculated by Equation (2): 19.2% in X-direction and 20.3% in Y-direction. At last, elastic analysis with viscous dampers can be implemented by a superposition of supplemental damping ratio and herein damping ratio 5%. Analysis results are listed in Table 8.

As the results show, this method will overrate responses of structure with viscous dampers: response spectrum analysis with supplemental damping ratio is much larger than dynamic history analysis with dampers, while dynamic history analysis with supplemental damping ratio can make a well approach with a percentage error below 15%. These errors can be attributed to the simplification that only the first natural period is taken into consideration and supplemental damping ratio of all modes is set to be the same while viscous dampers will provide a more high supplemental damping ratio to the structure under the high modes. Hence, this method will underassessm the supplemental damping ratio added by viscous dampers, and responses of structure are overrated. However, this simplification is

Table 8. Contrastive analysis results of each method

Analysis method	Response spectrum analysis		Dynamic history analysis		Dynamic history analysis	
	With supplemental damping ratio		With supplemental damping ratio		With dampers	
Condition	0	90	0	90	0	90
Direction (°)	0	90	0	90	0	90
Maximum storey drift (rad)	1/665	1/651	1/886	1/897	1/963	1/985
Top displacement (mm)	24.1	24.9	18.2	18.5	15.5	16.4
Base shear (kN)	26 820	26 098	19 336	18 626	16 918	16 162
Base moment (kN·m)	343 190	353 597	263 105	246 768	228 932	224 170

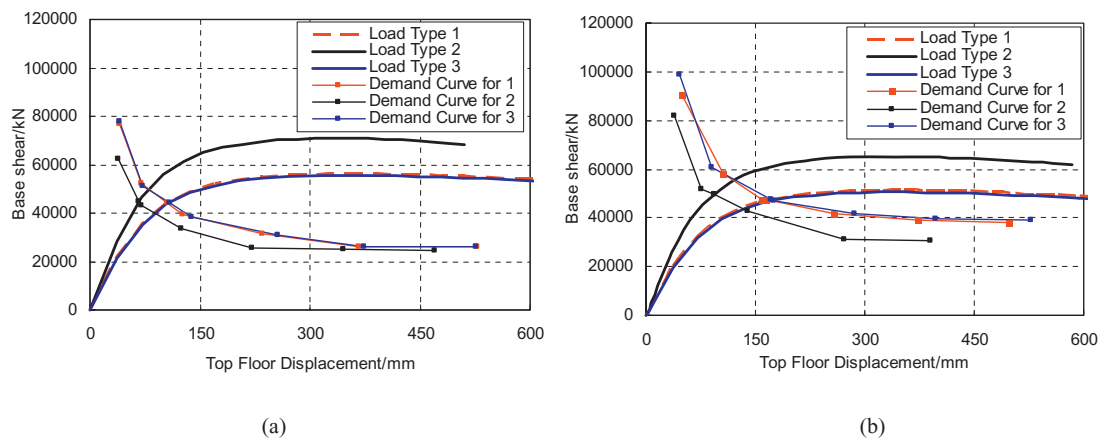

Figure 17. Structural static push capacity and demand check: (a) X direction; (b) Y direction (Load type 1—inverse-triangle; Load type 2—uniform; Load type 3—modal)

considered to be acceptable for the preliminary design of the supplemental dampers, whereas more vibration modes should be included in the final design check by the dynamic history analysis.

4.5 Static nonlinear analysis

In order to have a better understanding about lateral load resisting capacity of the structure, static nonlinear analysis (push-over) for the structure without viscous dampers is carried out in Perform-3D. And the analysis results can be also taken as a reference of the subsequent dynamic nonlinear analysis. Three types of load distribution shape are adopted, which are inverse-triangle, uniform and modal. Structural static push capacity check with three types of load distribution under rare earthquake is shown in Figure 17, where demand curve is generated through adopting response spectrum provided by Chinese Seismic Code. And the performance point is listed in Table 9, while structure performance at performance points is compared in Figure 18.

With a comparison of each analysis results, it is demonstrated that:

- (1) As to low structures with few storeys, demand of base shear obtained from each load distribution is identical, and the storey shear result of uniform distribution is smaller than two others in the above storeys. Analysis results of inverse-triangle and modal distribution is identical with each

Table 9. Performance point under different load distribution

Direction (°)	Performance point	Load distribution shape		
		Inverse-triangle	Uniform	Modal
0 (X)	Base shear (kN)	44 290	44 790	44 200
	Reference drift	1/176	1/277	1/170
	Maximum storey drift (rad)	1/138	1/218	1/133
	Top displacement (mm)	104.6	66.6	108.5
90 (Y)	Base shear (kN)	47 370	49 540	47 170
	Reference drift	1/112	1/197	1/110
	Maximum storey drift (rad)	1/86	1/150	1/84
	Top displacement (mm)	163.4	93.1	174.9

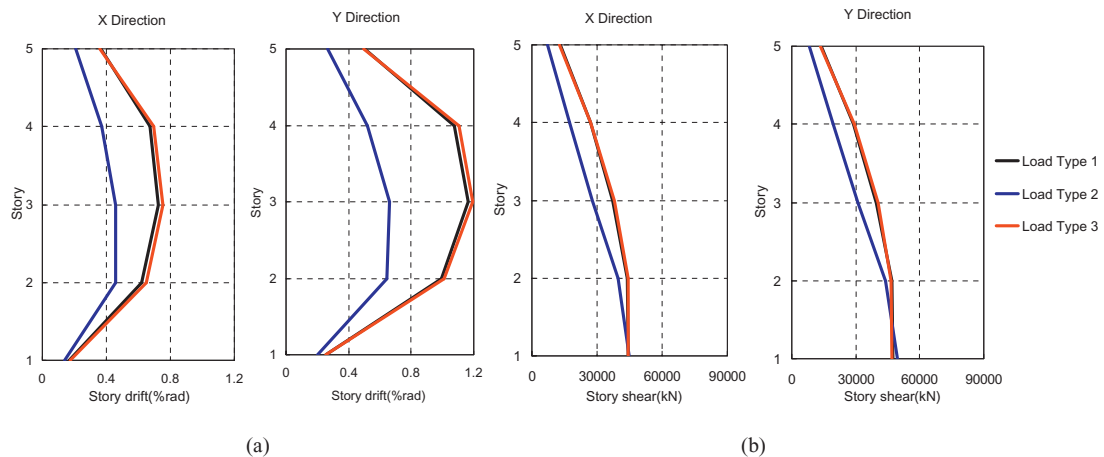

Figure 18. Structure performance at performance points: (a) storey drift curve; (b) storey shear curve (Load type 1—push-over with inverse-triangle distribution; Load type 2—push-over with uniform distribution; Load type 3—push-over with modal distribution)

other in general, while demand of drift and displacement obtained from inverse-triangle distribution is slightly smaller; however, demand of drift and displacement of uniform distribution is much smaller than two others. And this would lead to an unsafe assessment about structure.

- (2) Structure without viscous dampers has a performance point 44290 kN, 1/170, 108.5 mm at X-direction and a performance point 47370 kN, 1/110, 174.9 mm at Y-direction, which can be certified by the dynamic nonlinear analysis later. Besides, storey drift obtained from push-over analysis in two directions have both satisfied the limitation of codes 1/50. In other words, the deformation capacity of structure can meet the codes, and structure will perform well under rare earthquake and collapse can be prevented.
- (3) Elastic demand of structure without viscous dampers under rare earthquake of 8 degree seism is 79 575 kN, 75.2 mm at X-direction and 76 418 kN, 77.4 mm at Y-direction. The Wenchuan Hospital structure without viscous dampers is designed with an unyielding capacity under medium earthquake, and elastic demands of the structure are 40 673 kN, 38.4 mm at X-direction and 39 058 kN, 39.5 mm at Y-direction. Hence, the structure under rare earthquake of 8 degree seism cannot meet the elastic demand and energy will be dissipated by damage of structure. Finally, the structure can satisfy the performance objective due to a well deformation capacity.

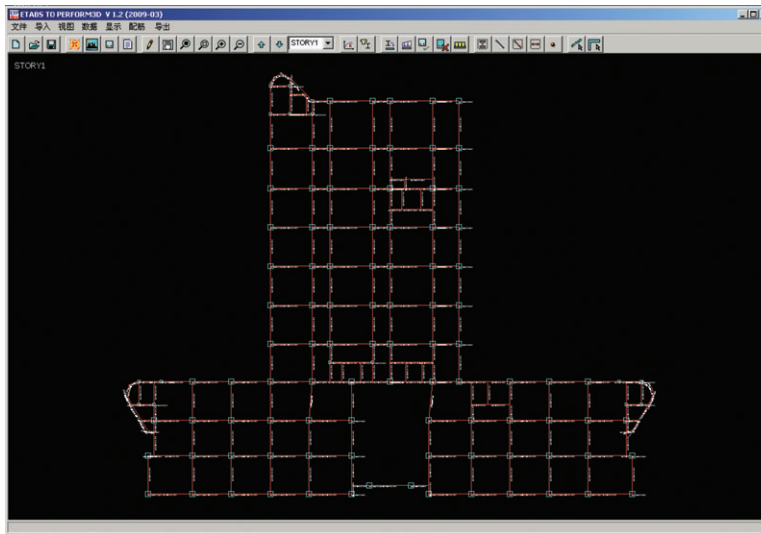

Figure 19. Interface of program ETP V1.2

4.6 Dynamic nonlinear analysis

Considering the importance of Wenchuan Hospital structure, dynamic nonlinear analysis is also carried out in Perform-3D to have a better understanding about seismic response of structure or members under rare earthquake. Besides, five groups of two-way natural seismic waves (GM1~GM5) used in elastic analysis are also adopted, and two-way seismic action is considered in both two main directions (0° and 90°). Finally, the average of dynamic nonlinear analysis results from each seismic wave can be taken as the performance level of structure.

A visualized modeling pre-processing program of Perform-3D named ETP V1.2 by which reinforcement of structure members can be conveniently imported is adopted, as shown in Figure 19. With this program, information of geometric, load, node, section, mass and restraint of the model which is modelled much more convenient in ETABS can be imported to Perform-3D, by which modelling nonlinear analysis model in Perform-3D can be improved both in efficiency and accuracy. Besides, version 1.2 of ETP has made a big improvement that reinforcement information can be imported into Perform-3D by reading the reinforcement text file exported by ETABS.

Analysis of elastic model with and without viscous dampers modelled in ETABS under the same condition is carried out to have a judgment of reliability and comparison of nonlinear response. In the condition numbered GM4X with a strong motion duration in the first 10 s, time history analysis result is presented, as shown in Figure 20:

- (1) Through comparison of inelastic and elastic analysis result, it can be seen that structure has an inelastic damage which indicated that structure has a degradation in stiffness while the period of it has a extension. This can be seen from the time-history result.
- (2) During the first 4 s, the top displacement and base shear of structure in nonlinear analysis is closed to the result in elastic analysis which indicate that the structure does not have an obvious plastic damage; and after 4 s, results of two models are separated which indicate that the structure has an obvious inelastic damage.
- (3) With a comparison about results of elastic-plastic model with and without dampers, it is certified that structure damage and responses can be reduced by adding viscous dampers.

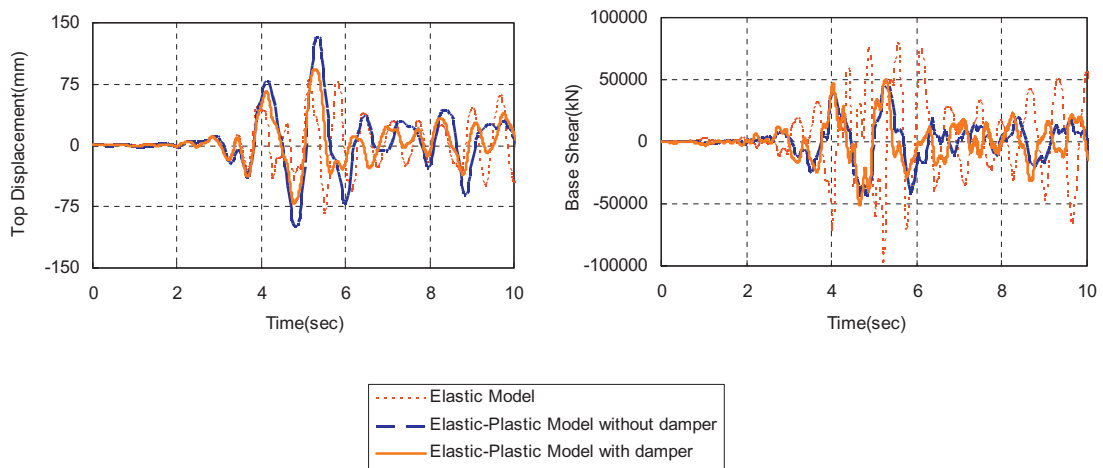

Figure 20. Time history responses of elastic and elastic-plastic structure model with and without damper under GM4X condition: (a) top displacement; (b) base shear

- (4) Base shear of elastic model is much larger than that of elastic-plastic model. And base shear of structure will not be decreased by adding viscous dampers; in other words, the viscous damper cannot reduce the energy inputting to structure.

As time increases, the difference between the results comes out to be obvious. Top displacement of elastic model reaches a peak value 83 mm, while top displacement of elastic-plastic model without dampers reaches a peak value 132 mm, and it can be decreased as 93 mm by adding viscous dampers. On the other hand, base shear of elastic model has a peak value 98 062 kN, while base shear of elastic-plastic model without dampers has a peak value 44 840 kN. Hence, it can be seen that base shear response of elastic model is as 2.2 times as larger as that of elastic-plastic model. Besides, base shear of elastic-plastic model with dampers will have a larger peak value 50 954 kN. The reason is that dynamic stiffness of structure is enlarged by adding viscous dampers which can strengthen the connection between K-brace-damper system and structure.

Based on the maximum internal force of elements recorded, expected performance levels of different structure members, such as bending and shear capacity of frame columns and beams with and without dampers, are verified. And a deformation check is carried out for those elements which could be yielded. Take condition GM4X (which has the largest input energy in the five seismic waves) for an example; the analysis results show that:

- (1) Structure without dampers has been in a strong plastic state and suffers a bigger damage with some elements, as shown in Figure 21(a, b). Specifically, most of frame beams are still in IO state; some of secondary beams are in LS state; most of frame columns are in IO state and some of them in bottom are in LS state; most of braces are in LS state with a large deformation but a small force.
- (2) The deformation of structure with dampers is sharply decreased, where all elements are in IO state and can meet the expected performance objective, as shown in Figure 21(c, d).

The analysis results of structure with and without dampers under rare earthquake are listed in Table 10, and response spectrum analysis results are also given as a reference. Comparison with three

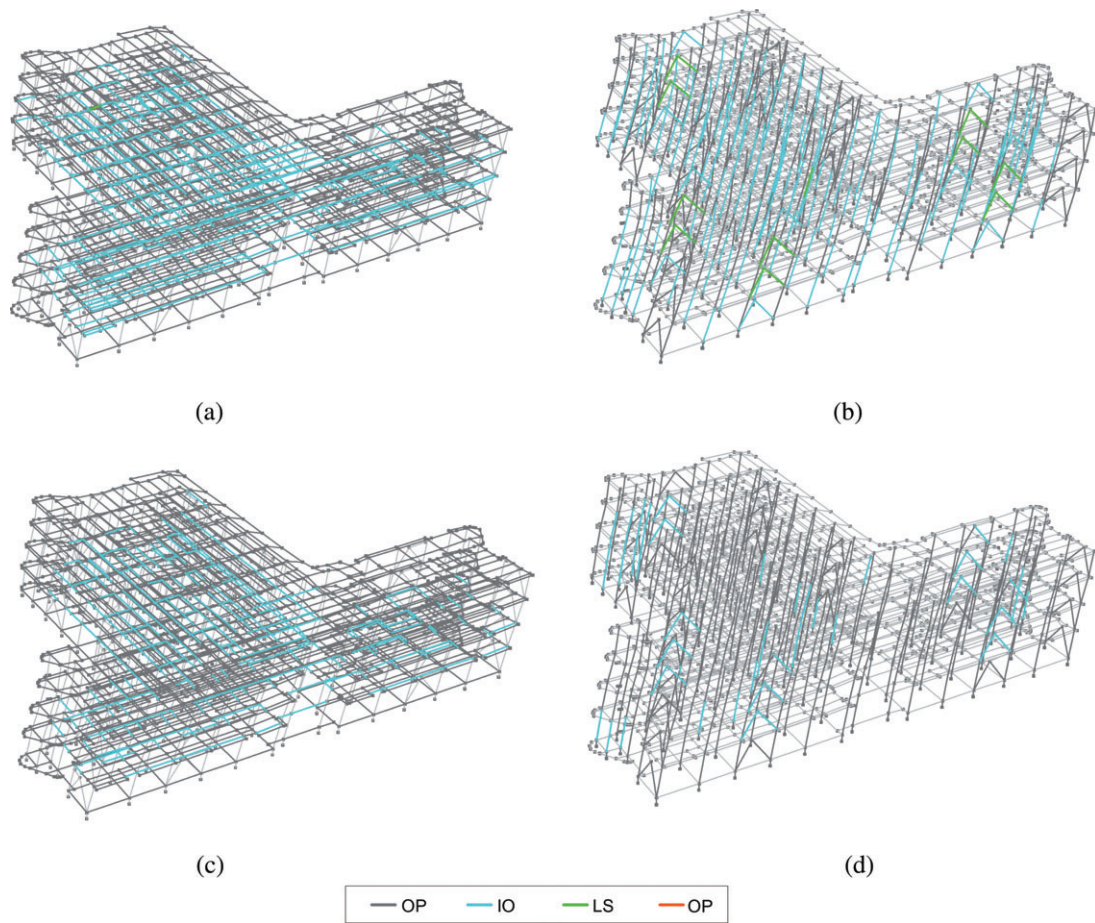

Figure 21. Performance of elements under condition GM4X: (a) Performance of frame beams, (b) Performance of frame columns and braces (Structure without dampers); (c) Performance of frame beams, (d) Performance of frame columns and braces (Structure with dampers)

Table 10. Main performance under rare earthquake

Analysis method	Response spectrum analysis		Dynamic nonlinear analysis			
	Without dampers		Without dampers		With dampers	
Dampers	Without dampers		Without dampers		With dampers	
Direction (°)	0	90	0	90	0	90
Maximum storey drift (rad)	1/212	1/198	1/186	1/168	1/237	1/218
Top displacement (mm)	75.2	77.4	81.8	89.8	63.4	70.3
Base shear (kN)	79 575	76 418	39 231	39 683	41 738	42 159
Base moment (kN/m)	1 057 042	1 096 806	475 575	470 640	513 664	498 960

conditions is indicated in Figure 22, together with two static nonlinear analysis results. Besides, energy dissipation of the whole structure (take condition GM4X, for an example) is shown in Figure 23.

The analysis results obtained from dynamic nonlinear analysis under rare earthquake show that:

- (1) Structure will turn into plastic state under rare earthquake, and the capacity of base shear cannot meet the demand base shear of elastic model. Hence, input energy will be dissipated by structure and members damage while structure has a well capacity of deformation.
- (2) As to low structure with few storeys, the response of structure is dominated by low modes. Hence, plastic deformation response will be larger than elastic deformation while the plastic demand of base shear will be much smaller than elastic demand. And building structure can be designed in more economic, more efficient and safer condition.
- (3) Energy can be well dissipated by viscous dampers with K-braces, and the deformation response and damage of structure can be reduced, as shown in Figures 20 and 22. Take GM4X for an example; dissipated inelastic energy is 37% of the input energy, which will cause damage with structure, while it can be reduced to 16% of input energy by adding viscous dampers, by which 41% of input energy is dissipated.
- (4) However, base shear and storey shear cannot have a similar reduction with deformation and remain or even become larger than that of structure without dampers (the reason is that dynamic stiffness of structure is enlarged by adding viscous dampers which can strengthen the connection between K-brace-damper system and structure, and so input energy will become larger). This can be found similarly in base moment as well.

After a comparative analysis with dynamic inelastic analysis (DIA) results and static nonlinear analysis under rare earthquake, it can be concluded that:

- (1) For the static nonlinear analysis with inverse-triangle distribution (Push-1), responses are larger than those of dynamic nonlinear analysis with structure without dampers. Specifically, maximum storey drift obtained from Push-1 is 34.7% larger than that of DIA in X-direction, while it is much

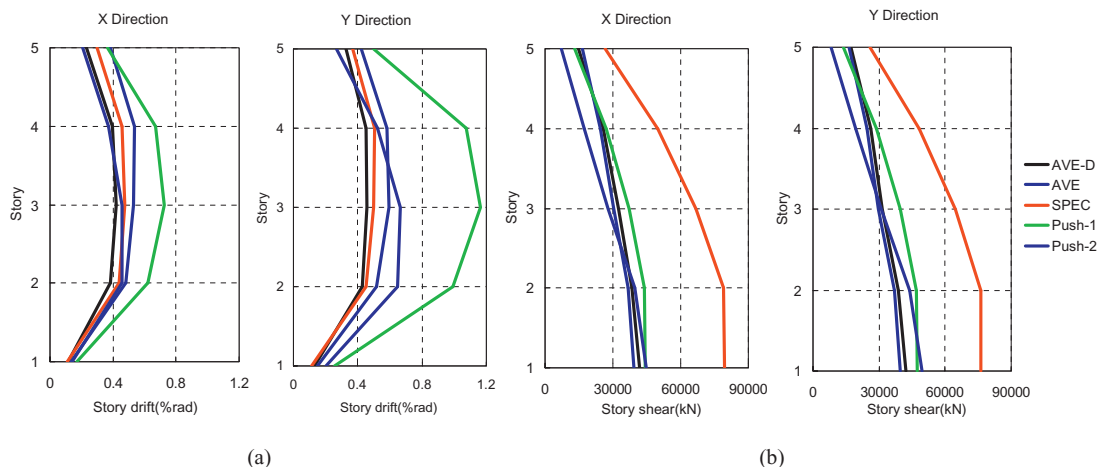
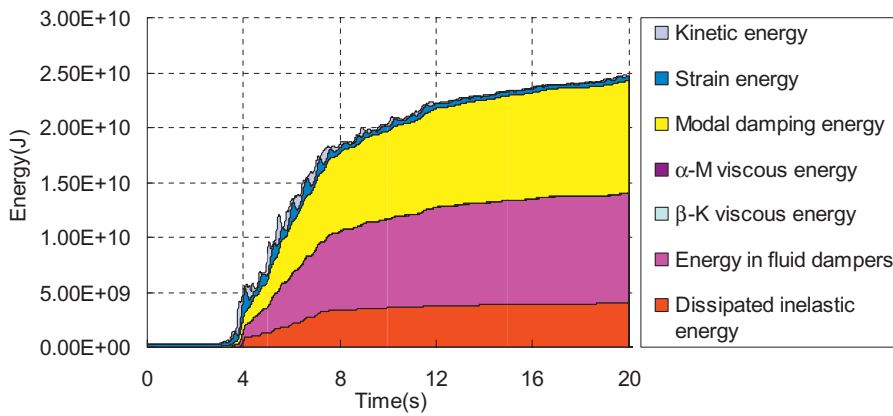
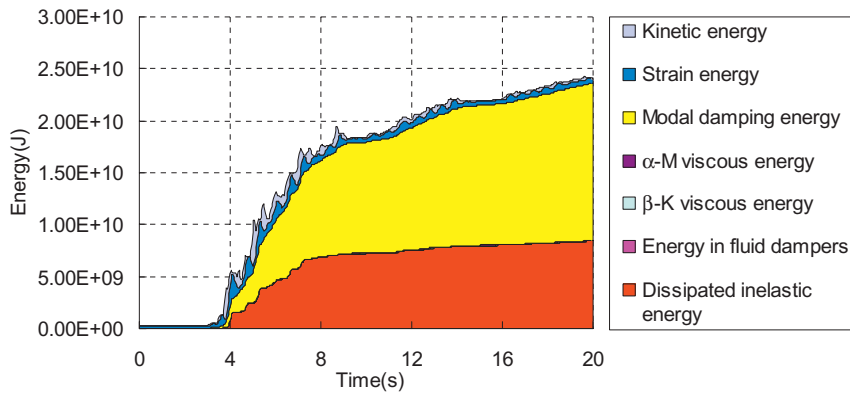

Figure 22. Structure performance under rare earthquake (dynamic nonlinear analysis): (a) storey drift curve; (b) storey shear curve. AVE-D, average response of structure with dampers; AVE, average response of structure without dampers; SPEC, response of elastic model with response spectrum analysis; Push-1: push-over with inverse-triangle distribution; Push-2: push-over with uniform distribution)



(a)



(b)

Figure 23. Energy dissipation (under GM4X condition): (a) structure without dampers; (b) structure with dampers

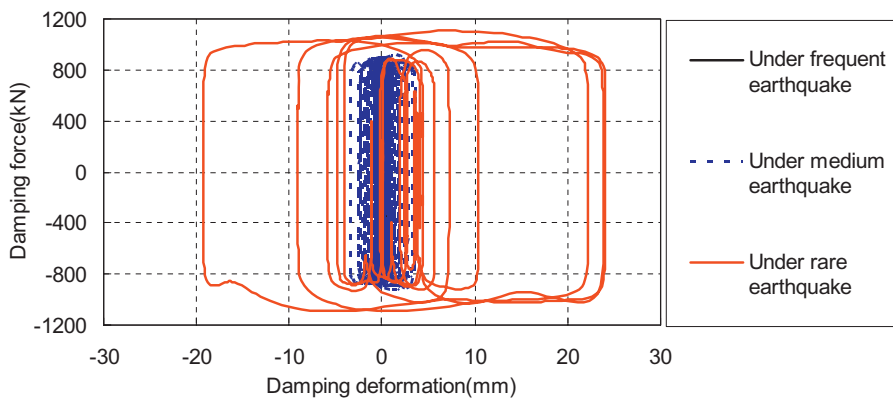

Figure 24. Energy dissipation in typical dampers (Under GM4X): (a) working condition under frequent earthquake; (b) working condition under medium earthquake, (c) working condition under rare earthquake

larger with a percentage of 95% in Y-direction. As to base shear, results of Push-1 are larger with a percentage of 13% in X-direction and 19% in Y-direction. Besides, results of Push-1 can be enveloped values of DIA results.

- (2) As to the static nonlinear analysis with uniform distribution (Push-2), responses are not always lower than that of DIA with structure without dampers. That is, maximum storey drift obtained from Push-2 is 14% smaller than that of DIA in X-direction, while it is 12% larger in Y-direction. As to base shear, results of Push-2 are 14% larger in X-direction and 25% in Y-direction. And storey shear and drift of Push-2 cannot be enveloped values of DIA results, while the responses in above storeys are lower than those of DIA, as shown in Figure 21.

Altogether, the results of Push-1 are certified that the static nonlinear analysis is believable which will make a more conservative and safer assessment for structure; while results of Push-2 will under-assess the response of structure, especially in the above storeys.

4.6 Working state of braces and viscous dampers

With checking calculation under rare earthquake, axial force and deformation of braces are 1638.0 kN and 2.06 mm, respectively. The maximum stress in section is 100 MPa (considered the effective length of braces). The maximum damping force of viscous dampers is 1106.0 kN, while maximum deformation is 24.0 mm, as shown in Figure 24. Hence, it can be certified that viscous dampers are working in safety under rare earthquake.

5. CONCLUSION

RC frame with 46 viscous dampers structure is adopted in Wenchuan Hospital, and a comprehensive analysis based on performance is carried out in this paper. Based on the results of analysis in many aspects, it can be concluded that:

- (1) A practical method using ETABS V9.1.2 to calculate the supplemental damping ratio added by viscous dampers is proposed in this paper, and the analysis result shows that the result obtained from this method is considered to be acceptable for the preliminary design of the supplemental dampers.
- (2) Based on elastic analysis results of structures with and without dampers under frequent and medium earthquake, it can be seen that the response of structures without dampers cannot meet the limit values required in the codes under medium earthquake, such as storey drift and member force; while it can be satisfied by adding viscous dampers, such as storey drift, top displacement and so on. And performance objectives can be achieved through the elastic and unyielded analysis under medium earthquake.
- (3) A comparison about static nonlinear analysis under three types of load distribution is presented. It can be seen that responses of inverse-triangle and modal distribution are similar to each other while responses of uniform distribution are much smaller than two others. In contrast with the dynamic nonlinear analysis, it is reasonable that modal or inverse-triangle load distribution is adopted to get the performance of structure, which will make a more conservative and safer assessment for structure. Hence, dynamic nonlinear analysis should be added to have a more precise seismic assessment of structure, and a more accurate procedure for push-over analysis should be recommended for seismic assessment of structure in practice.
- (4) Dynamic nonlinear analysis can be carried out in Perform-3D by which performance-based analysis can be effectively carried out to obtain and assess the seismic response of structure with or without dampers.

- (5) From the comparison of elastic and nonlinear analyses results, it can be known that results are reliable, and structural plastic damage can be reduced by adding viscous dampers. It can be seen that viscous dampers will be more efficient to a structure under elastic state under frequent and medium earthquake in contrast with that of a structure having gone into a plastic state under rare earthquake.
- (6) As to low structure with few storeys which is dominated by lower modes, deformation responses will be enlarged after the structure going into plastic state, while inter-force will increase nonlinearly (deformation increases faster than inter-force). Deformation responses can be effectively reduced by adding viscous dampers, while inter-force will not decrease but have an increase; the reason is that dynamic stiffness of structure is enlarged by adding viscous dampers which can strengthen the connection between K-brace-damper system and structure. As to a structure whose high modes are easily excited, both deformation and inter-force responses are reduced after structure going into plastic state because of the high modes' affection. And then both deformation and inter-force responses can be reduced by adding viscous dampers.

REFERENCES

- American Society of Civil Engineers. 2006. Minimum design loads for buildings and other structures (*ASCE/SEI 7-05*). American Society of Civil Engineers: Reston, VA.
- American Society of Civil Engineers. 2007. Seismic rehabilitation of existing buildings (*ASCE/SEI 41/06*). American Society of Civil Engineers: Reston, VA.
- Bai ZZ, AU FTK, Kwan AKH. 2007. Complete nonlinear response of reinforced concrete beams under cyclic loading. *The Structural Design of Tall and Special Buildings* **16**: 107–130.
- Computer and Structures, Inc. 2006. *Perform-3D, Nonlinear Analysis and Performance Assessment for 3D Structure User Guide, Version 4*. Computers and Structures, Inc.: Berkeley, CA.
- Computer and Structures, Inc. 2007. *ETABS, Extended 3D Analysis and Performance Assessment for 3D Structures User Guide, Version 9.1.6*. Computers and Structures, Inc.: Berkeley, CA.
- Constantinou M, Symans M. 1992. Experimental and analytical investigation of seismic response of structures with supplemental fluid viscous dampers. *Technical Report NCERR-92-0032*.
- Constantinou MC, Hammel P, Sigaher W. 2001. Toggle-brace-damper seismic energy dissipation systems. *Journal of Structural Engineering* **127**(2): 105–112.
- Federal Emergency Management Agency (FEMA). 1997. NEHRP guidelines for the seismic rehabilitation of buildings. *Report no. 273/274*, Building Seismic Safety Council, Washington, D.C.
- Federal Emergency Management Agency (FEMA). 2000. Pre-standard and commentary for the seismic rehabilitation of buildings. *FEMA 356*, Washington, D.C.
- National General Rule of PRC. 2004. General rule for performance-based seismic design of buildings (*CECSI60:2004*). China Architecture & Building Press: Beijing.
- National Standard of PRC. 2001. Code for seismic design of buildings (*GB50011-2001*). China Architecture & Building Press: Beijing.
- National Standard of PRC. 2002. Load Code for the design of building structures. (*GB50009-2001*). China Architecture & Building Press: Beijing.
- Seleemah AA, Constantinou MC. 1997. 'Investigation of seismic response of buildings with linear and nonlinear fluid viscous dampers.' *Rep. No. NCEER-97-0004*. National Center for Earthquake Research, State University of New York at Buffalo, Buffalo, N.Y.
- Soong TL, Constantinou MC. 1994. *Passive and active structural vibration control in civil engineering*. Spring, New York.
- Structural Engineers Association of Northern California. 2007. Recommended administrative bulletin on the seismic design and review of tall buildings using non-prescriptive procedures.
- Taylor DP. 2007. Douglas P. Taylor. *The Structural Design of Tall and Special Buildings* **16**: 37–82.